



Issuing Entity:  
Larson International Inc.  
P.O. Box 638  
Plainview, TX 79073-0638  
U.S.A.  
Phone 806-293-1353  
Fax 806-293-5215  
www.larsonintl.com

Bulletin No.: L03-002  
Release Date: 02/24/03  
Effective Date: Immediately  
Supersedes: N/A  
Completion Date: N/A

Page: 1 of 2

# SERVICE BULLETIN

**Ride Manufacturer: Larson International, Inc. Affected Production Dates: All**  
**Ride Name: Ring of Fire & Crazy Train Affected Serial Nos.: All units**

**Ride Manufacturer: Hi Roller Company Affected Production Dates: All**  
**Ride Name: Hi roller & Ring of Fire Affected Serial Nos.: All units**

**Ride Manufacturer: LMC, Inc. Affected Production Dates: All**  
**Ride Name: Super Loops Affected Serial Nos.: All units**

**Abstract Of Issue:**  
**Mandatory daily inspection of lap bar padding.**

**Reason for Release:**  
**Certain operators have allowed rides to operate despite severely worn lap bar padding. This poses a threat of injury or death if the riders are not properly restrained due to worn padding.**

**Action To Be Taken:**  
**Inspect lap bar padding on a daily basis. Replace padding if:**

- 1. The foam padding does not hold its memory.**
- 2. The foam padding is worn or torn to the point it will not hold a passenger in their seat firmly.**
- 3. The foam padding is torn internally such that the padding hangs or sags from the shaft that is to run through the center of the padding.**
- 4. The foam padding is egg-shaped or sagging and is no longer cylindrical in shape.**

**Minor damage to the upholstery cover is permissible as long as it does not pose a threat to passenger safety.**

Larson International Inc. issues notifications for the benefit of owners of amusement rides manufactured by Larson International, Inc. As a service to the industry, and in the interest of employee and public safety, Larson International, Inc. also issues notifications for the benefit of owners of amusement ride equipment for which the manufacturer no longer exists such as LMC, Inc. and Hi-Roller Company. In doing so, Larson International, Inc. does not assume liability for losses associated with amusement ride equipment built by manufacturers other than Larson International, Inc.

**Detail Of Issue:  
(Text/Drawings/Schematics)**

**TYPICAL HI ROLLER DOOR  
IS AS SHOWN.  
LAP BAR RESTRAINT IS  
CONSISTANT WITH THAT  
OF THE RING OF FIRE, SUPER  
LOOP, AND CRAZY TRAIN.**

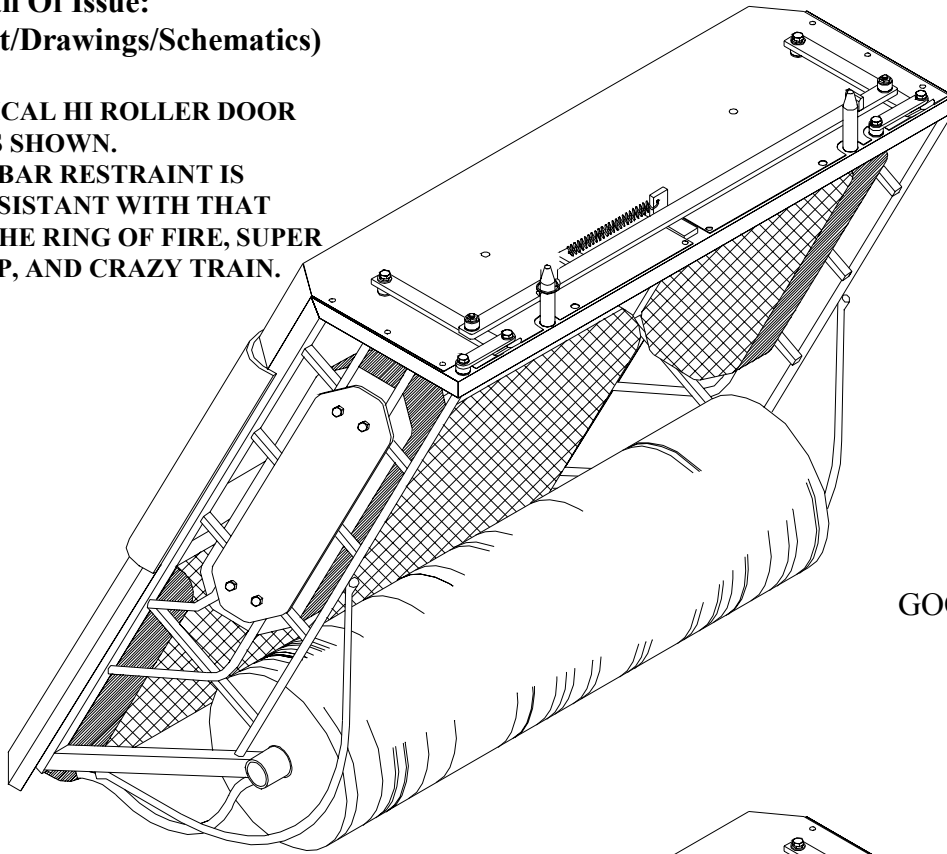

GOOD CONDITION

